

Архангельск (8182)63-90-72
Астана (7172)727-132
Астрахань (8512)99-46-04
Барнаул (3852)73-04-60
Белгород (4722)40-23-64
Брянск (4832)59-03-52
Владивосток (423)249-28-31
Волгоград (844)278-03-48
Вологда (8172)26-41-59
Воронеж (473)204-51-73
Екатеринбург (343)384-55-89
Иваново (4932)77-34-06

Ижевск (3412)26-03-58
Иркутск (395)279-98-46
Казань (843)206-01-48
Калининград (4012)72-03-81
Калуга (4842)92-23-67
Кемерово (3842)65-04-62
Киров (8332)68-02-04
Краснодар (861)203-40-90
Красноярск (391)204-63-61
Курск (4712)77-13-04
Липецк (4742)52-20-81

Киргизия (996)312-96-26-47

Магнитогорск (3519)55-03-13
Москва (495)268-04-70
Мурманск (8152)59-64-93
Набережные Челны (8552)20-53-41
Нижний Новгород (831)429-08-12
Новокузнецк (3843)20-46-81
Новосибирск (383)227-86-73
Омск (3812)21-46-40
Орел (4862)44-53-42
Оренбург (3532)37-68-04
Пенза (8412)22-31-16

Россия (495)268-04-70

Пермь (342)205-81-47
Ростов-на-Дону (863)308-18-15
Рязань (4912)46-61-64
Самара (846)206-03-16
Санкт-Петербург (812)309-46-40
Саратов (845)249-38-78
Севастополь (8692)22-31-93
Симферополь (3652)67-13-56
Смоленск (4812)29-41-54
Сочи (862)225-72-31
Ставрополь (8652)20-65-13

Казахстан (772)734-952-31

Сургут (3462)77-98-35
Тверь (4822)63-31-35
Томск (3822)98-41-53
Тула (4872)74-02-29
Тюмень (3452)66-21-18
Ульяновск (8422)24-23-59
Уфа (347)229-48-12
Хабаровск (4212)92-98-04
Челябинск (351)202-03-61
Череповец (8202)49-02-64
Ярославль (4852)69-52-93

www.sft.nt-rt.ru | | sfq@nt-rt.ru

Технические характеристики на перезаряжаемые литий-ионные аккумуляторы высокой мощности МР, схемы защиты отдельных ячеек

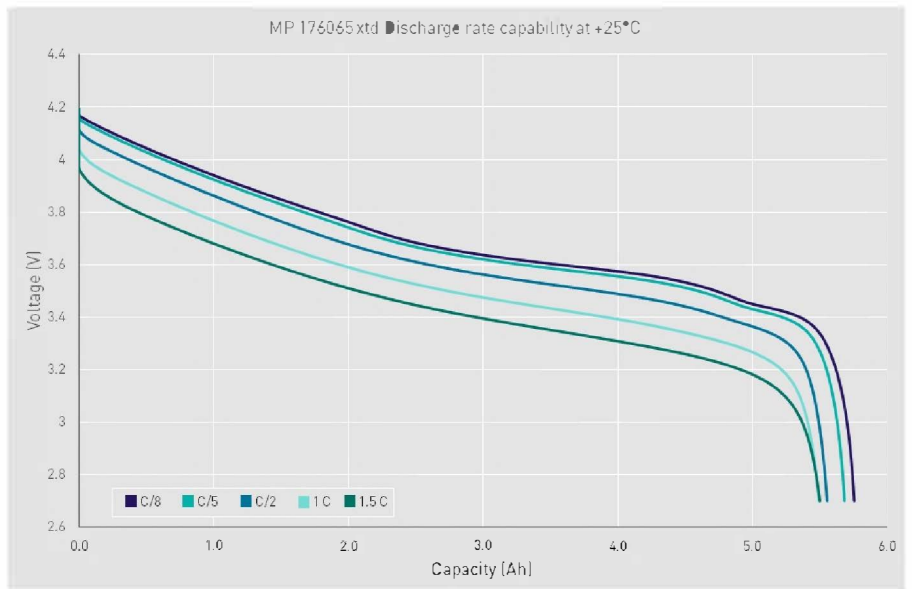
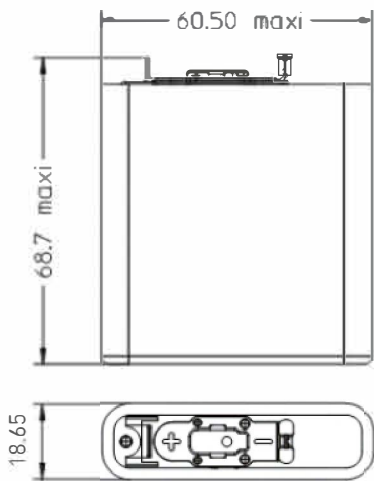

Battery assembly

Individual lithium-ion cells need to be mechanically and electrically integrated into battery systems to operate properly. The battery system includes electronic devices for performance, thermal and safety management specific to each application. Please contact us for your specific applications requirements.

Battery-level features

- provides complete battery system designs
- Incorporating several levels of redundant safety features to prevent abuse conditions such as over-charge, over-discharge, and short circuits
- Incorporating electronics for performance and efficiency:
 - charge/floating/discharge management
 - cell balancing
 - temperature monitoring
- Battery protection controller at system level
 - Communication for State-of-Charge and State-of-Health

Storage

- The storage area should be clean, cool (preferably not exceeding +30°C), dry and ventilated

Warning

- Do not crush, short-circuit, incinerate, dismantle, immerse in any liquid, heat above +85°C
- Observe charging conditions

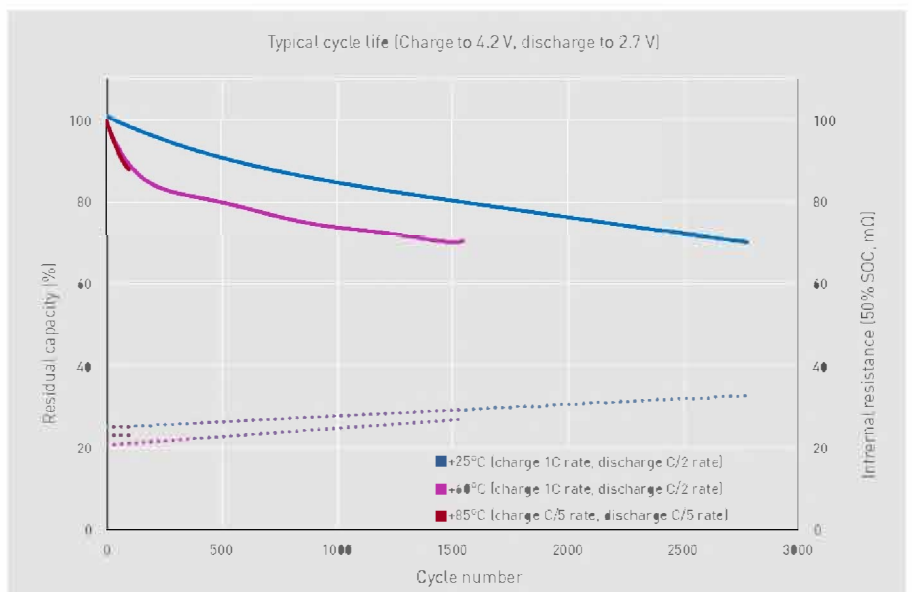
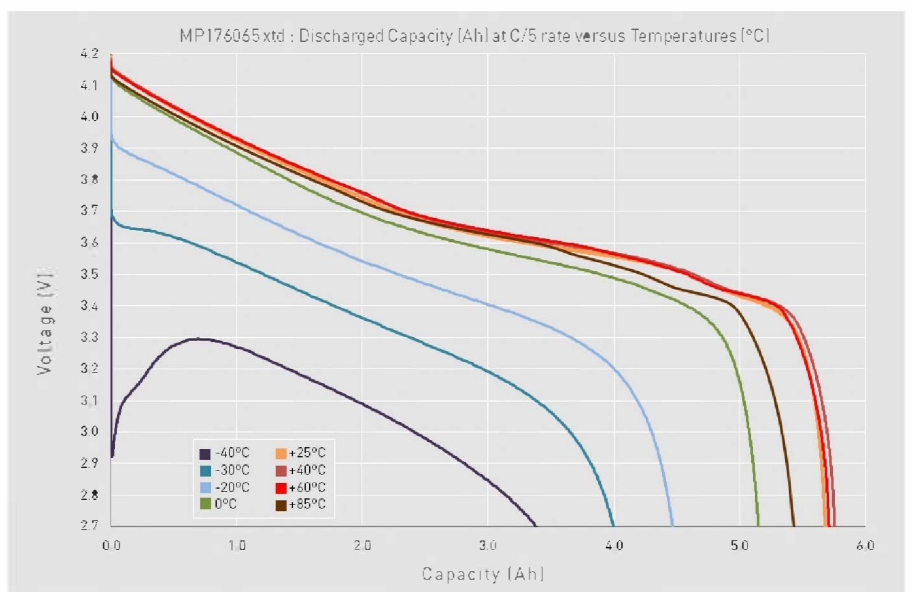

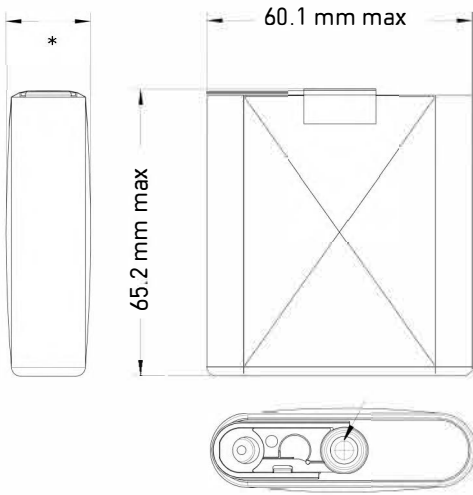

Cell dimensions*

During the lifetime of the cell, in different applications some dimensions may alter slightly. Please consult with for further details.

Battery assembly

Individual lithium-ion cells need to be mechanically and electrically integrated into battery systems to operate properly. The battery system includes electronic devices for performance, thermal and safety management specific to each application. Please contact with your specific application requirements.

Battery-level features

- provides complete battery system designs
- Integrating several levels of redundant safety features to prevent abuse conditions such as over-charge, over-discharge, and short circuits
- Incorporating electronics for performance and efficiency in charging, floating, discharging as well as cell balancing and temperature monitoring
- Battery protection controller at system level for larger batteries
- Communication for State-of-Charge and State-of-Health

Storage

- The storage area should be clean, cool (preferably not exceeding +30°C), dry and ventilated

Warning

- Do not crush, short-circuit, incinerate, dismantle, immerse in any liquid, heat above +60°C
- Observe charging conditions
- Refer to our Li-ion Battery User manual for further information on the use and handling of products.

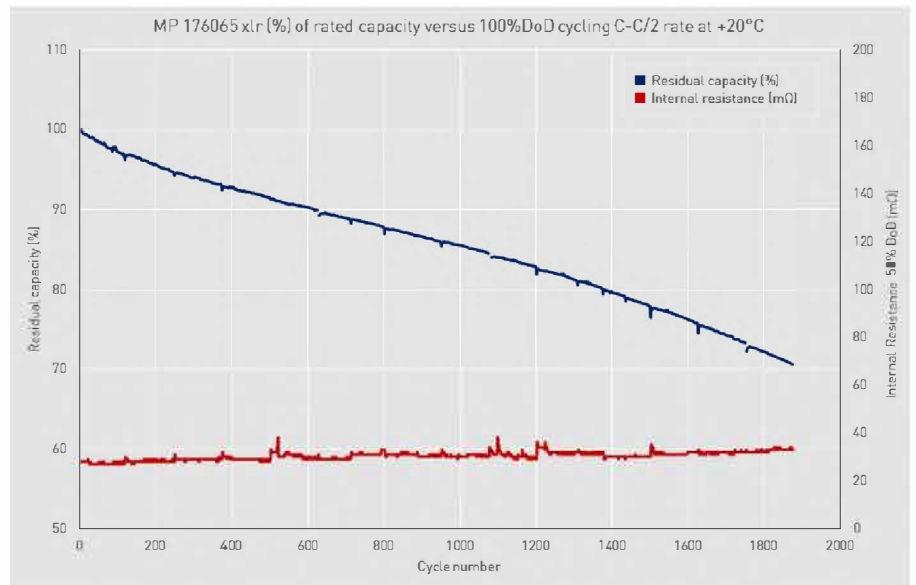
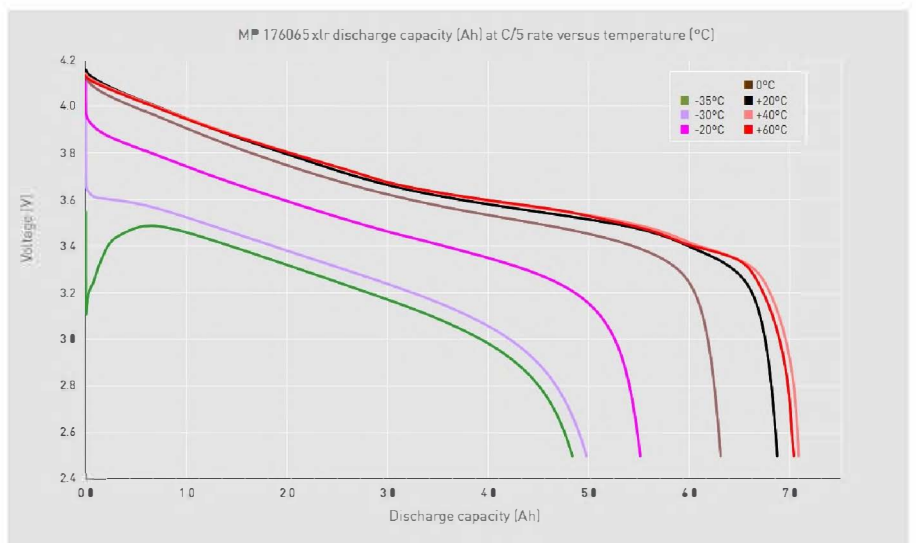
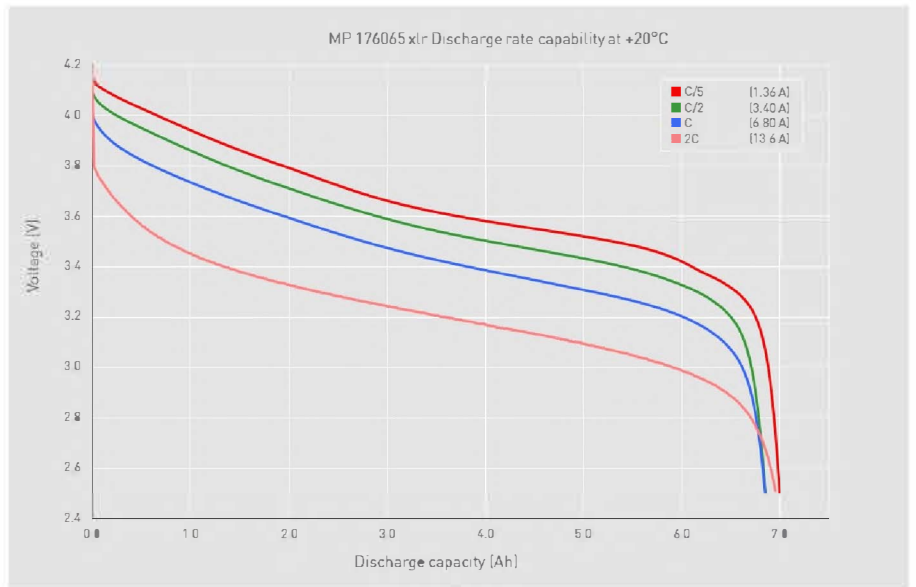

MP 176065 ise

Rechargeable Li-ion cell

3.65 V high energy Li-ion cell with high performance and **intrinsic safety**

Saft's MP 176065 ise cell is compatible with applications requiring intrinsic safety, long operating life under cycling conditions and offers excellent performance in temperature environments from -30°C to $+60^{\circ}\text{C}$.

Benefits

- Excellent operating lifetime in cycling with a very stable internal resistance
- High level of safety, compatible with potentially explosive atmospheres
- Long shelf life with extremely low capacity loss in storage
- Easy connection and assembly into batteries
- Smaller environmental footprint than other technologies

Key features

- High energy density (264 Wh/l, and 150 Wh/kg)
- Cycle life more than 1000 tested (≥ 2250 expected) cycles at 100% DoD at C/2 discharge, C charge
- Aluminium casing
- Hermetically sealed
- Operates in any orientation
- Maintenance free
- No memory effect
- Manufactured in the EU

Designed to meet all major quality, safety and environmental standards

- Safety: UL 1642 and IEC62133-2:2017
- Transport: UN 3480, UN 38.3
- ATEX^[v] IEC 60079-11 (10.5.2, 10.5.3 (b)) compatible component
- Quality: ISO 9001, Saft World Class program.
- Environment: ISO 14001, RoHS and REACH compliant

Typical applications

- Backup for industrial equipment
- Medical devices
- Tracking
- Oil & Gas applications
- Internet of Things, Wireless Sensor Networks
- Lighting & signalling



Electrical characteristics

Typical capacity [at C/5 rate, $+25^{\circ}\text{C}$, 2.5V cut-off] ^[i]	5.6 Ah	
Nominal voltage	3.65 V	
Nominal energy	20.4 Wh	
Recommended maximum discharge current ^[ii]	Continuous	11 A [$\sim 2\text{C}$ rate]
	Pulse	22A [$\sim 4\text{C}$ rate]

Physical characteristics [sleeved cell]

Thickness ^[iii]	19.05 mm	
Width	60.5 mm	
Height (including terminals)	68.7 mm	
Typical weight	135 g	
Volume (including terminals)	0.077 l	
IEC cell designation	INP/19/61/69	
Saft internal designation	INT 176065 ise	
Saft part number	70374V	
Saft model / type reference	MP 176065 ise	GP31591

Operating conditions

Typical cut-off voltage	2.5 V	
Charging method	Constant current/Constant voltage	
Charging voltage	4.2 ± 0.05 V	
Maximum continuous charge current ^[iv]	5.6 A [$\sim 1\text{C}$ rate]	
Operating temperatures	Charge	-30°C to $+60^{\circ}\text{C}$
	Discharge	-30°C to $+60^{\circ}\text{C}$
Storage & transportation temperatures	Recommended	$+10^{\circ}\text{C}$ to $+30^{\circ}\text{C}$
	Allowable	-40°C to $+60^{\circ}\text{C}$

[i] Can vary depending on temperature and discharge rate

[ii] Can vary depending on temperatures. Consult

[iii] At beginning of life, 100% State-of-Charge. May increase with temperature and the cells' calendar life.

[iv] For optimised charging below 0°C and $+60^{\circ}\text{C}$, consult

[v] Compatible with a temperature classification T4 for an ambient temperature of 60°C . The temperature classification shall be verified during the assessment of the intrinsically safe apparatus in which the cell will be used.



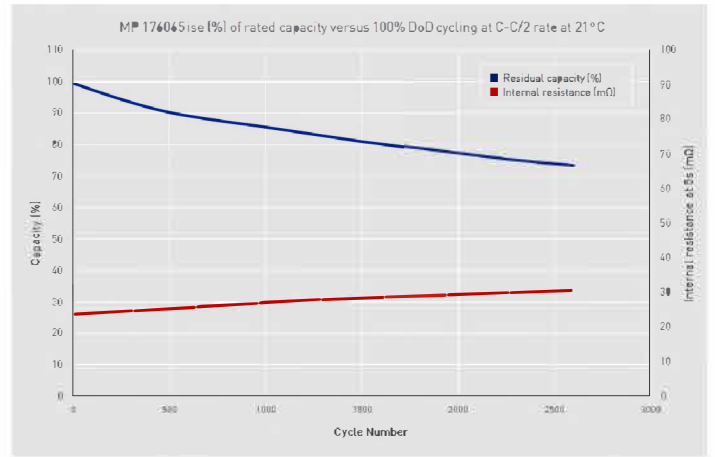
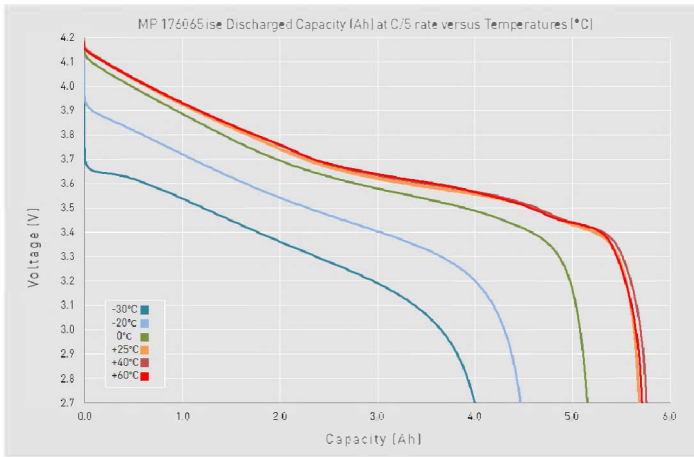

Battery assembly

- Individual lithium-ion cells need to be mechanically and electrically integrated into battery systems to operate properly.
- The battery system includes electronic devices for performance, thermal and safety management specific to each application.
- Please contact for your specific application requirements.

Cell surface temperature and spark ignition

- The cell can be compatible with the temperature classification T4 at an ambient temperature of +60°C.
- The temperature classification shall be verified during the assessment of the intrinsic safety apparatus in which the cell will be used.
- The spark ignition risk shall be verified during the assessment of the intrinsic safety apparatus in which the cell will be used.

Storage

- The storage area should be clean, cool (preferably not exceeding +30°C), dry and ventilated. For long term storage, keep the cell within a 30 ± 15% state of charge

Warning

- Do not crush, short-circuit, incinerate, dismantle, immerse in any liquid or heat above +60°C
- Observe charging conditions at all times

Pretest conditions	Value
Test chamber temperature	60 °C
Cell state of charge	100 %
Short circuit resistance	2.76 mΩ

Test data recorded	Value (max)
Maximum current	247.4 A
Cell maximum temperature	112.4 °C

Test results	Result
Temperature >100 °C and ≤135 °C	Temperature class T4
Externally visible electrolyte ≥24 h	No visible electrolyte
Discharge current interruption	No partial discharge
IECEx ExTR Reference No.	FR/INE/ExTR18.0024/00

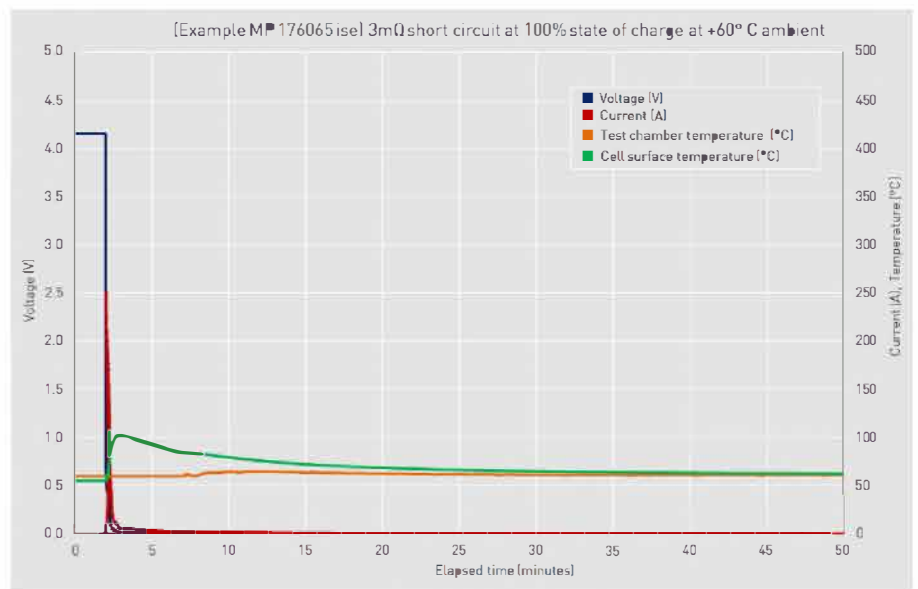

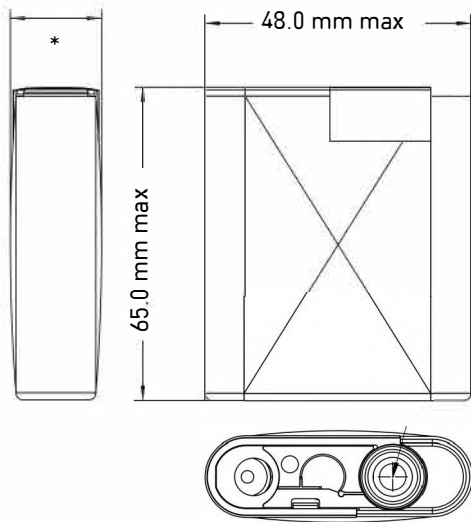

Cell dimensions*

During the lifetime of the cell, in different applications some dimensions may alter slightly. Please consult with for further details.

Battery assembly

Individual lithium-ion cells need to be mechanically and electrically integrated into battery systems to operate properly. The battery system includes electronic devices for performance, thermal and safety management specific to each application. Please contact with your specific application requirements.

Battery-level features

- provides complete battery system designs
- Integrating several levels of redundant safety features to prevent abuse conditions such as over-charge, over-discharge, and short circuits
- Incorporating electronics for performance and efficiency in charging, floating, discharging as well as cell balancing and temperature monitoring
- Battery protection controller at system level for larger batteries
- Communication for State-of-Charge and State-of-Health

Storage

- The storage area should be clean, cool (preferably not exceeding +30°C), dry and ventilated

Warning

- Do not crush, short-circuit, incinerate, dismantle, immerse in any liquid, or heat above +60°C
- Observe charging conditions
- Refer to our Li-ion Battery User manual for further information on the use and handling of products.

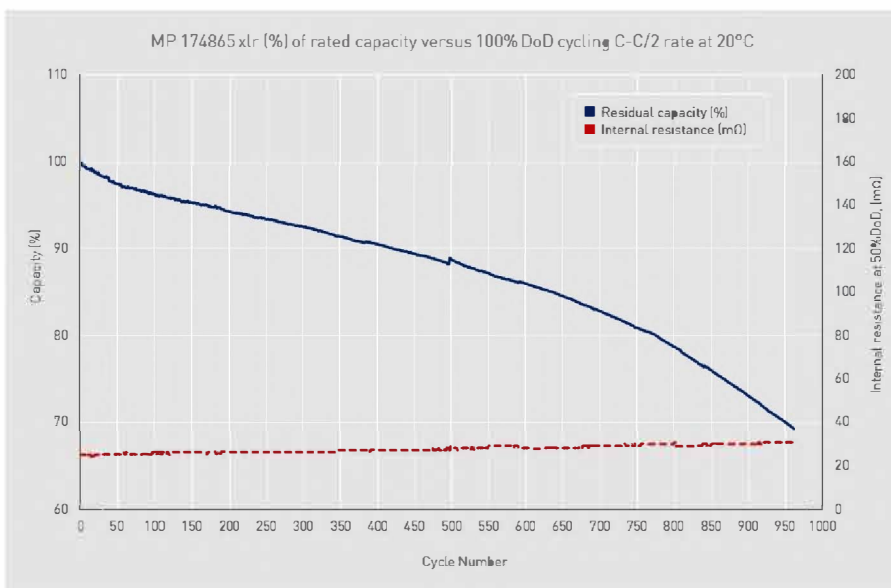
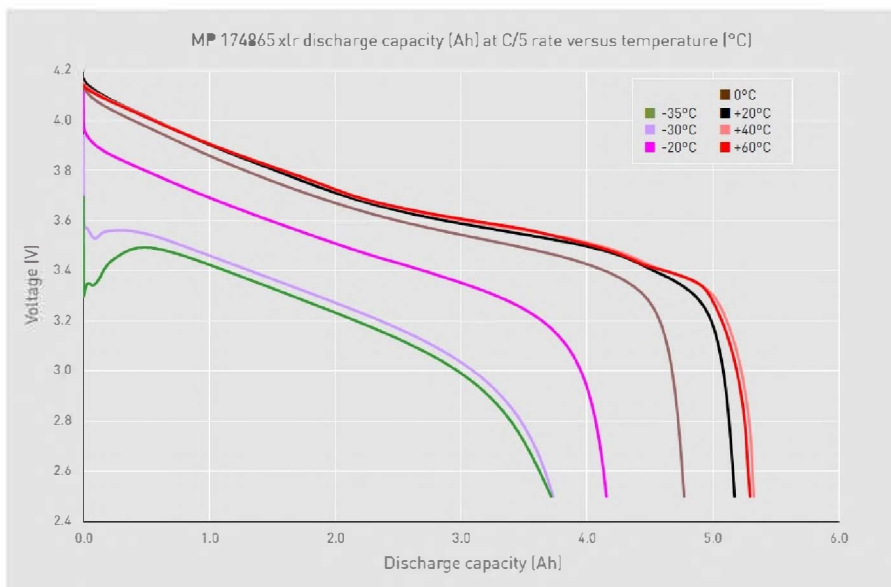
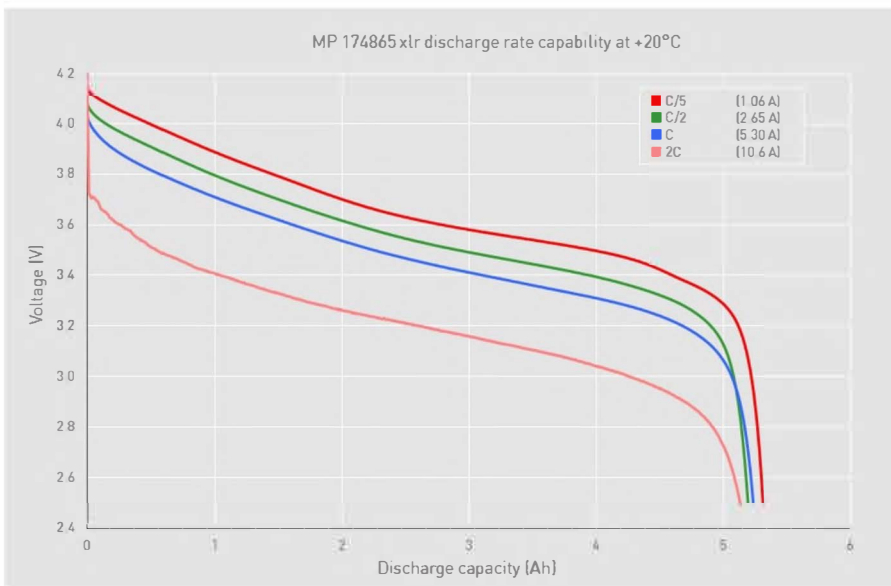

MP 174565 xtd

Rechargeable Li-ion cell

3.65 V high energy Li-ion cell with extra life and operational temperature

Saft's MP 174565 xtd cell is ideally suited for applications requiring high energy and long operating life, either in calendar, cycling or floating conditions, with excellent performance in unregulated temperature environments from -40°C to $+85^{\circ}\text{C}$.

Benefits

- Excellent operating life in calendar, cycling and floating conditions
- Unrivalled operating temperature range from -40°C to $+85^{\circ}\text{C}$
- Long shelf life with extremely low capacity loss under storage
- Easy assembly into various designs and formats of batteries.
- Smaller environmental footprint than other technologies

Key features

- High energy density (264 Wh/l, and 150 Wh/kg)
- Aluminium casing
- Hermetically sealed
- Operates in any orientation
- Maintenance free
- No memory effect
- Manufactured in the EU

Designed to meet all major quality, safety and environmental standards

- Safety: UL 1642 and IEC 62133 Ed. 2
- Transport: UN 3480, UN 3481
- Quality: ISO 9001, ISO 13485
Saft World Class program
- Environment: ISO 14001, RoHS and REACH compliant

Typical applications

- Backup systems for industrial and commercial equipment
- Medical devices
- Tracking
- Industrial applications
- Internet of Things
- Wireless Sensor Networks
- Lighting & signalling



Electrical characteristics

Typical capacity (at C/5 rate, $+25^{\circ}\text{C}$, 2.5V cut-off) ^[i]	4.0 Ah	
Nominal voltage	3.65 V	
Nominal energy	14.6 Wh	
Recommended maximum discharge current ^[ii]	Continuous	8 A ($\sim 2\text{C}$ rate)
	Pulse	16 A ($\sim 4\text{C}$ rate)

Physical characteristics (sleeved cell)

Thickness ^[iii]	18.65 mm	
Width	45.3 mm	
Height (including terminals)	68.5 mm	
Typical weight	97 g	
Volume (including terminals)	0.057 l	
IEC cell designation	INP19/46/69	
Saft internal cell designation	INT 174565 xtd	
Saft part number	07946G	
Saft model / type reference	MP 174565 xtd	GP30612

Operating conditions

Typical cut-off voltage	2.5 V	
Charging method	Constant current/Constant voltage	
Charging voltage	4.2 V	
Maximum continuous charge current ^[iv]	4 A ($\sim 1\text{C}$ rate)	
Operating temperatures	Charge	-30°C to $+85^{\circ}\text{C}$
	Discharge	-40°C to $+85^{\circ}\text{C}$
Storage & transportation temperatures	Recommended	$+15^{\circ}\text{C}$ to $+30^{\circ}\text{C}$
	Allowable	-40°C to $+85^{\circ}\text{C}$

[i] Can vary depending on temperature and discharge rate

[ii] Can vary depending on temperatures. Consult

[iii] At beginning of life, 100% State-of-Charge. May increase with temperature and the cells' calendar life.

[iv] For optimised charging below 0°C and above $+60^{\circ}\text{C}$, consult



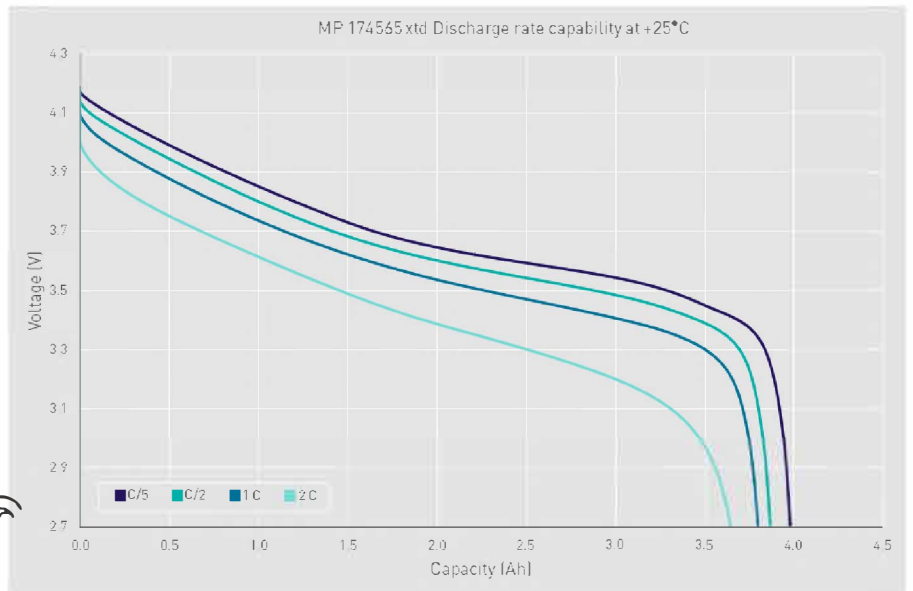
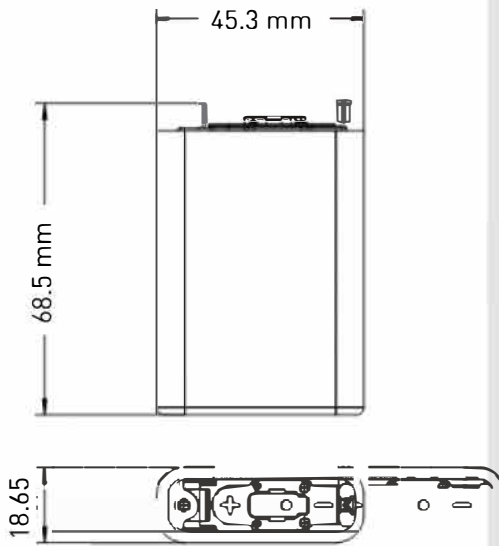

Battery assembly

Individual lithium-ion cells need to be mechanically and electrically assembled into battery systems to operate properly. The battery system includes electronic devices for performance, thermal and safety management specific to each application. Please contact for your specific applications requirements.

Battery-level features

- provides complete battery system designs
- Incorporating several levels of redundant safety features to prevent abuse conditions such as over-charge, over-discharge, and short circuits

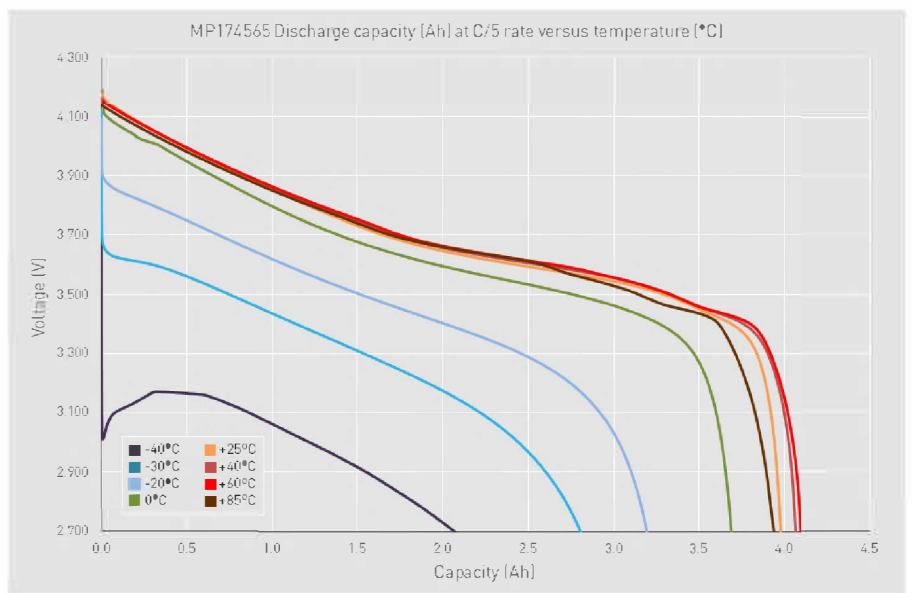

Storage

- The storage area should be clean, cool (preferably not exceeding +30°C), dry and ventilated

Warning

- Do not crush, short-circuit, incinerate, dismantle, immerse in any liquid, heat above +85°C
- Observe charging conditions

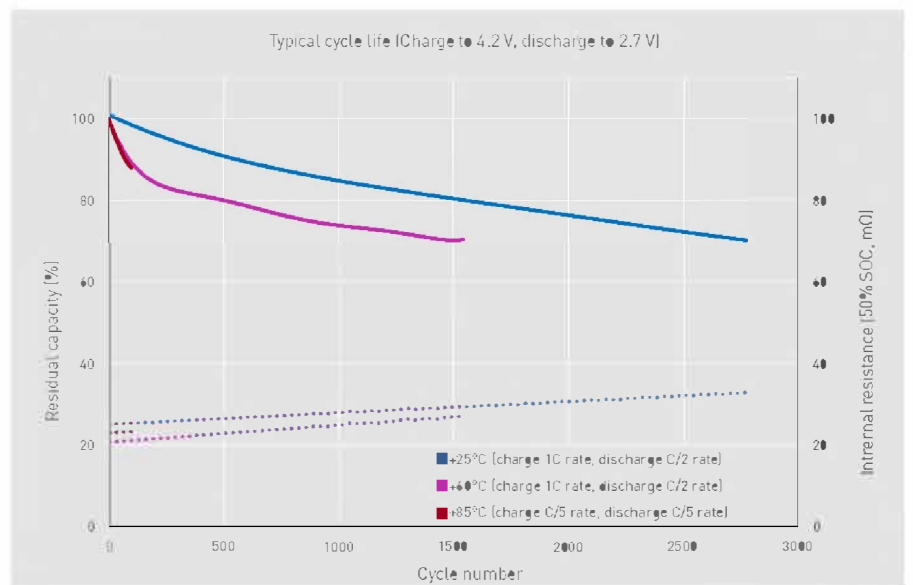

MP 174565 xtd CliP System

Rechargeable Li-ion battery

3.65 V high energy Li-ion battery with an integrated enclosure

Saft's MP 174565 xtd CliP System 1s1p battery retains all of the extreme environmental operating conditions of the cell, plus it has its own mechanically integrated enclosure system. Built strong for tough environments.

Benefits

- Excellent operating life in calendar, cycling ($\geq 2,700$ 100% DoD cycles) and float charging conditions
- Unrivalled operating temperature range from -40°C to $+85^{\circ}\text{C}$
- High level of safety, compatible with potentially explosive atmospheres
- Long shelf life with extremely low capacity loss under storage
- Easy integration
- Smaller environmental footprint than other technologies

Key features

- High energy density (264 Wh/l, and 150 Wh/kg)
- Aluminium casing
- Hermetically sealed
- Operates in any orientation
- Maintenance free
- No memory effect
- Manufactured in EU

Designed to meet all major quality, safety and environmental standards

- Safety: UL 1642 and IEC62133 Ed. 2
- Transport: UN 3480, UN 3481
- Quality: ISO 9001, ISO 13485 World Class program
- Environment: ISO 14001, RoHS and REACH compliant

Typical applications

- Backup for industrial equipment
- Medical devices
- Tracking
- Oil & Gas applications
- Internet of Things
- Wireless Sensor Networks
- Lighting & signalling



Electrical characteristics

Typical capacity [at C/5 rate, $+25^{\circ}\text{C}$, 2.5V cut-off] ⁽¹⁾	4.0 Ah
Nominal voltage	3.65 V
Nominal energy	14.6 Wh
Recommended maximum discharge current ⁽²⁾	Continuous 5 A

Physical characteristics (sleeved cell)

Thickness ⁽³⁾	20.0 mm
Width	51.0 mm
Height (not including cable and connector)	75.0 mm
Volume (not including cable and connector)	0.076 l
Typical weight	116 g
IEC battery designation	11NP20/51/75
part number	07943D

Operating conditions

Typical cut-off voltage	2.5 V
Charging method	Constant current/Constant voltage
Charging voltage	4.2 V
Maximum continuous charge current ⁽⁴⁾	4 A (~1C rate)
Operating temperatures	Charge -30°C to $+85^{\circ}\text{C}$ Discharge -40°C to $+85^{\circ}\text{C}$
Storage & transportation temperatures	Recommended $+15^{\circ}\text{C}$ to $+30^{\circ}\text{C}$ Allowable -40°C to $+85^{\circ}\text{C}$

⁽¹⁾ Can vary depending on temperature and discharge rate.

⁽²⁾ Limited by the electronic protection circuit. Consult for other possibilities.

⁽³⁾ At beginning of life, 100% State-of-Charge. Can increase with temperature and the cells' calendar life.

⁽⁴⁾ For optimised charging below 0°C and above 60°C , consult.

CliP System cell enclosure

Battery assembly

The CliP System is designed to reduce the cost of assembly by removing the requirement to provide an overall heat shrink cover to mechanically protect a 1s1p battery. The CliP provides mechanical protection for all six sides, corners and the electronic protection circuit.

Battery-level features

- provides complete battery system designs
- Incorporating several levels of redundant safety features to prevent abuse conditions such as over-charge, over-discharge and short circuits

Storage

- The storage area should be clean, cool (preferably not exceeding +30°C), dry and ventilated

Warning

- Do not crush, short-circuit, incinerate, dismantle, immerse in any liquid, heat above +85°C
- Observe charging conditions

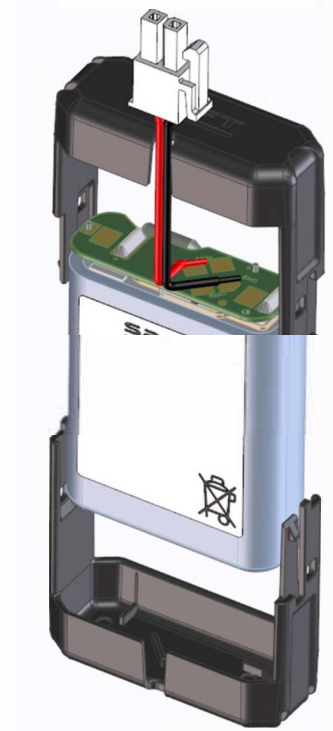
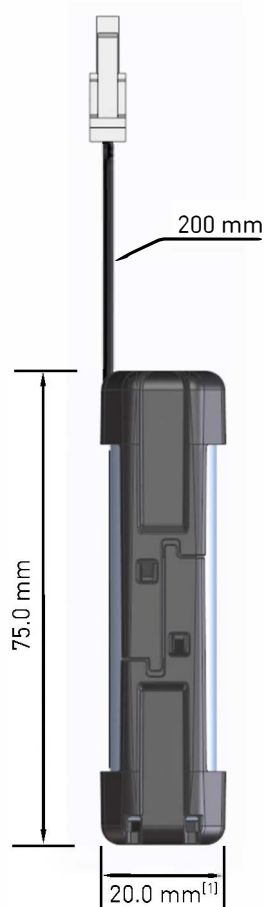

Description	Conditions	Thickness ^[1]
At beginning of life	25°C at 30% state of charge 3.7 V	18.65 mm
At beginning of life	25°C at 100% state of charge 4.2 V	18.80 mm
At 700 cycles	25°C charged C - C 4.2 V—2.7 V	19.25 mm
On continuous float charge	60°C at 4.2V after 1 year	20.75 mm
At 100 cycles	85°C charged C/5 - C/5 4.1 V-2.7 V	21.45 mm
Height	Maximum height	75.00 mm
Width	Maximum width	51.00 mm
Thickness ^[1]	Maximum housing thickness	20.00 mm
Connector (Male)	Molex Mini-Fit Jr. ref. 39-01-2020	
Connector (Female)	Molex Mini-Fit Jr. ref. 39-00-0038	

MP 174565 ise

Rechargeable Li-ion cell

3.65 V high energy Li-ion cell with high performance and **intrinsic safety**

Saft's MP 174565 ise cell is compatible with applications requiring intrinsic safety, long operating life under cycling conditions and offers excellent performance in temperature environments from -30°C to +60°C.

Benefits

- Excellent operating lifetime in calendar and cycling with a very stable internal resistance
- High level of safety, compatible with potentially explosive atmospheres
- Long shelf life with extremely low capacity loss in storage
- Easy connection and assembly into batteries
- Smaller environmental footprint than other technologies

Key features

- High energy density (256 Wh/l, and 150 Wh/kg)
- Cycle life of 2300 cycles at 100% DoD at C/2 discharge, C charge
- Aluminium casing
- Hermetically sealed
- Operates in any orientation
- Maintenance free
- No memory effect
- **Manufactured in the EU**

Designed to meet all major quality, safety and environmental standards

- Safety: UL 1642 and IEC 62133-2:2017
- Transport: UN 3480, UN 38.3
- ATEX^(v) IEC 60079-11 (10.5.2, 10.5.3 (b)) compatible component
- Quality: ISO 9001
Saft World Class program
- Environment: ISO 14001, RoHS and REACH compliant

Typical applications

- Backup for industrial equipment
- Medical devices
- Tracking
- Oil & Gas applications
- Internet of Things
- Wireless Sensor Networks
- Lighting & signalling
- Automotive

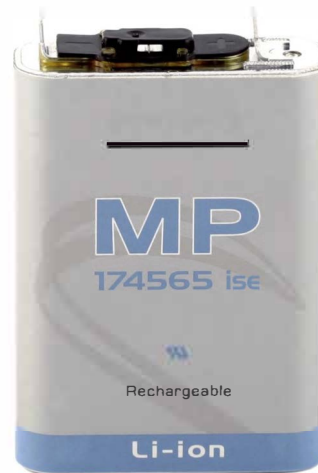

Electrical characteristics

Typical capacity [at C/5 rate, +25°C, 2.5V cut-off] ⁽ⁱ⁾	4.0 Ah	
Nominal voltage	3.65 V	
Nominal energy	14.6 Wh	
Recommended maximum discharge current ⁽ⁱⁱ⁾	Continuous	8 A (~2C rate)
	Pulse	16 A (~4C rate)

Physical characteristics (sleeved cell)

Thickness ⁽ⁱⁱⁱ⁾	18.65 mm	
Width	45.3 mm	
Height (including terminals)	68.5 mm	
Typical weight	97 g	
Volume (including terminals)	0.057 l	
IEC cell designation	INP19/46/69	
Saft internal cell designation	INT 174565 ise	
Saft part number	70373U	
Saft model / type reference	MP 174565 ise	GP31347

Operating conditions

Typical cut-off voltage	2.5 V	
Charging method	Constant current/Constant voltage	
Charging voltage	4.2 ± 0.05 V	
Maximum continuous charge current ^(iv)	4 A (~1C rate)	
Operating temperatures	Charge	-30°C to +60°C
	Discharge	-30°C to +60°C
Storage & transportation temperatures	Recommended	+10°C to +30°C
	Allowable	-40°C to +60°C

[i] Can vary depending on temperature and discharge rate

[ii] Can vary depending on temperatures. Consult

[iii] At beginning of life, 100% State-of-Charge. May increase with temperature and the cells' calendar life.

[iv] For optimised charging below 0°C and +60°C, consult

[v] Compatible with the temperature classification T4 for an ambient temperature of 60°C. The temperature classification shall be verified during the assessment of the intrinsic safety apparatus in which the cell will be used.



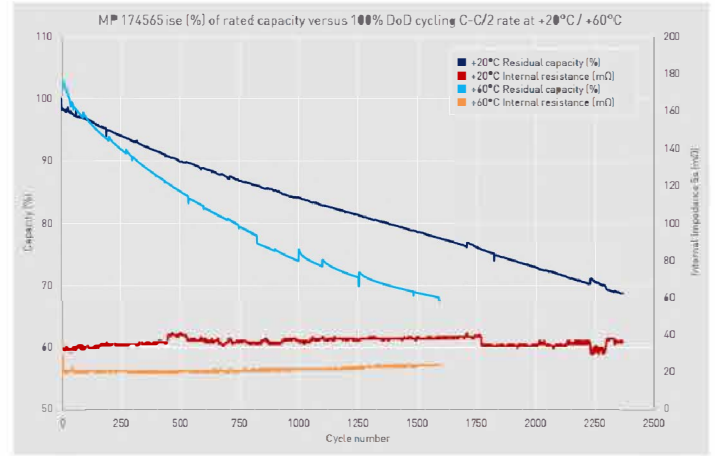
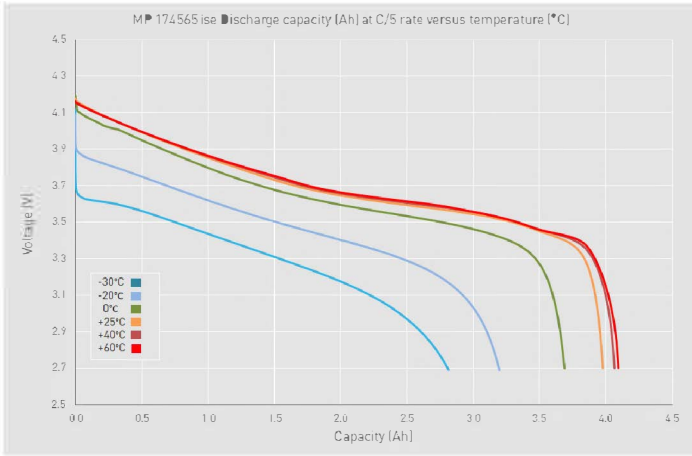

Battery assembly

- Individual lithium-ion cells need to be mechanically and electrically integrated into battery systems to operate properly.
- The battery system includes electronic devices for performance, thermal and safety management specific to each application.
- Please contact for your specific application requirements.

Cell surface temperature and spark ignition

- The cell can be compatible with the temperature classification T4 at an ambient temperature of +60°C.
- The temperature classification shall be verified during the assessment of the intrinsic safety apparatus in which the cell will be used.
- The spark ignition risk shall be verified during the assessment of the intrinsic safety apparatus in which the cell will be used.

Storage

- The storage area should be clean, cool (preferably not exceeding +30°C), dry and ventilated. For long term storage, keep the cell within a 30 ± 15% state of charge

Warning

- Do not crush, short-circuit, incinerate, dismantle, immerse in any liquid or heat above +60°C
- Observe charging conditions at all times

Pretest conditions	Value
Test chamber temperature	60 °C
Cell state of charge	100 %
Short circuit resistance	2.82 mΩ

Test data recorded	Value (max)
Maximum current	278.6 A
Cell maximum temperature	112.9 °C

Test results	Result
Temperature >100 °C and ≤135 °C	Temperature class T4
Externally visible electrolyte ≥24 h	No visible electrolyte
Discharge current interruption	No partial discharge
IECEx ExTR Reference No.	FR/INE/ExTR18.0022/00

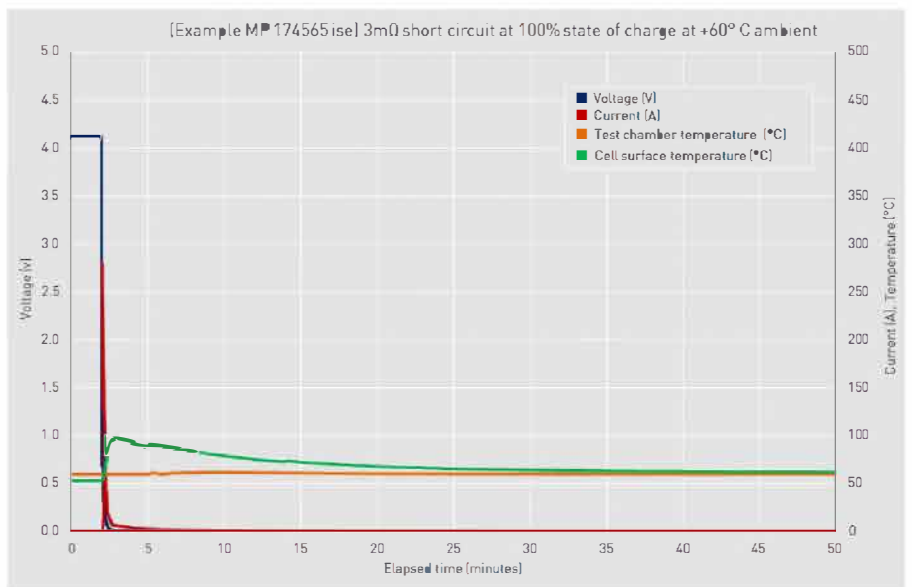

MP 144350 xlr

Rechargeable Li-ion cell

3.65 V high energy Li-ion cell with robust performance and cycle life

Saft's MP 144350 xlr cell is ideally suited for applications requiring high energy, long operating life under cycling conditions and offers excellent performance in temperature environments from -35°C to +60°C.

Benefits

- Excellent operating lifetime in calendar and cycling with a very stable internal resistance
- High level of safety, compatible in potentially explosive atmospheres
- Long shelf life with extremely low capacity loss under storage
- Easy connection and assembly into batteries
- Smaller environmental footprint than other technologies

Key features

- High energy density (335 Wh/l and 142 Wh/kg)
- Cycle life more than 1100 cycles at 100% DoD at C/2 discharge, C/ charge
- Stainless Steel casing
- Hermetically sealed
- Maintenance free
- No memory effect
- Manufactured in EU

Designed to meet all major quality, safety and environmental standards

- Safety: UL 1642 and IEC62133 Ed.2
- Transport: UN 3480, UN 3481
- Medical: ISO 13485
- Quality: ISO 9001, World Class
- Environment: ISO 14001, RoHS and REACH compliant

Typical applications

- Industrial equipment
- Medical devices
- Oil & Gas applications
- Internet of Things devices
- Wireless Sensor Networks
- Military equipment

Electrical characteristics

Typical capacity (at C/5 rate, +25°C, 2.5V cut-off) ⁽¹⁾	2.6 Ah
Nominal voltage	3.65 V
Nominal energy	9.4 Wh
Recommended maximum discharge current ⁽²⁾	Continuous 5.0 A (~2C rate) Pulses 10.0 A (~4C rate)

Physical characteristics (sleeved cell)

Thickness ⁽³⁾	14.5 mm
Width	42.9 mm
Height (including terminals)	50.1 mm
Typical weight	~66 g
Volume (including terminals)	0.028 l
IEC cell designation	INP15/43/51

Operating conditions

Typical cut-off voltage	2.5 V
Charging method	Constant current / Constant voltage
Charging voltage	4.2 ± 0.05 V
Maximum continuous charge current ⁽⁴⁾	2.6 A (1C rate)
Operating temperatures ⁽⁴⁾	Charge -30°C to +60°C Discharge -35°C to +60°C
Storage & transportation temperatures ⁽⁴⁾	Recommended +10°C to +30°C Allowable -40°C to +60°C

⁽¹⁾ Can vary depending on temperature and discharge rate

⁽²⁾ Can vary depending on temperatures. Consult

⁽³⁾ At beginning of life, 100% State-of-Charge. Can increase with temperature and during battery life.

⁽⁴⁾ For optimised operation below 0°C consult

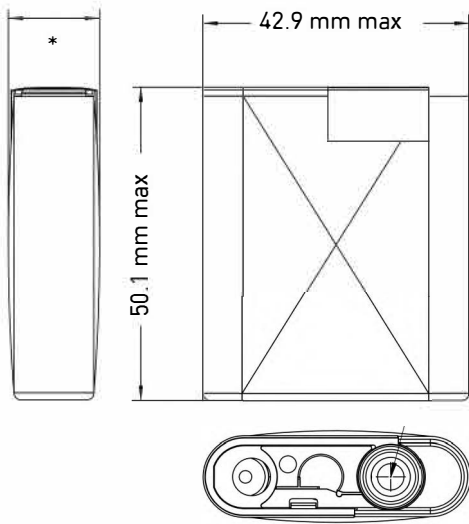

Cell dimensions*

During the lifetime of the cell, in different applications some dimensions may alter slightly. Please consult with for further details.

Battery assembly

Individual lithium-ion cells need to be mechanically and electrically integrated into battery systems to operate properly. The battery system includes electronic devices for performance, thermal and safety management specific to each application. Please contact with your specific application requirements.

Battery-level features

- provides complete battery system designs
- Integrating several levels of redundant safety features to prevent abuse conditions such as over-charge, over-discharge, and short circuits
- Incorporating electronics for performance and efficiency in charging, floating, discharging as well as cell balancing and temperature monitoring
- Battery protection controller at system level for larger batteries
- Communication for State-of-Charge and State-of-Health

Storage

- The storage area should be clean, cool (preferably not exceeding +30°C), dry and ventilated

Warning

- Do not crush, short-circuit, incinerate, dismantle, immerse in any liquid, heat above +60°C
- Observe charging conditions
- Refer to our Li-ion Battery User manual for further information on the use and handling of products.

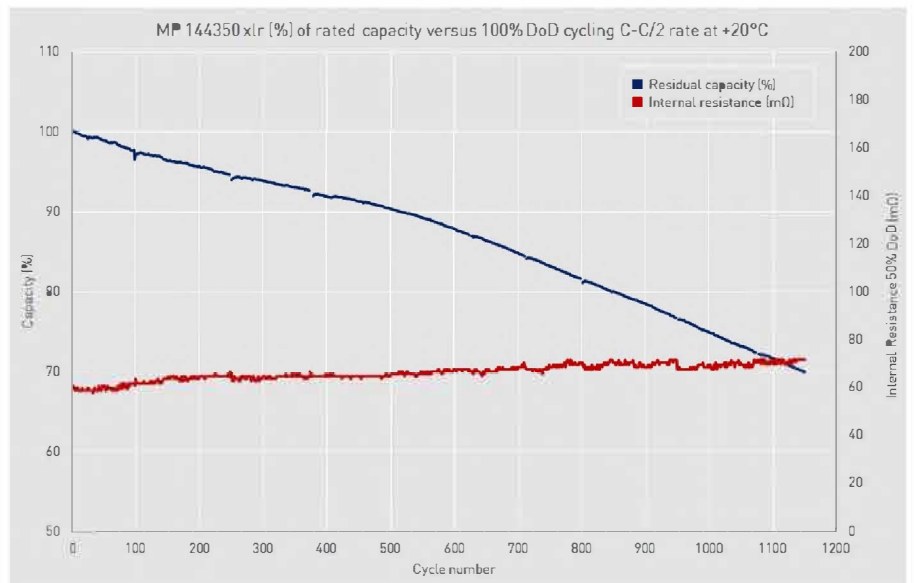
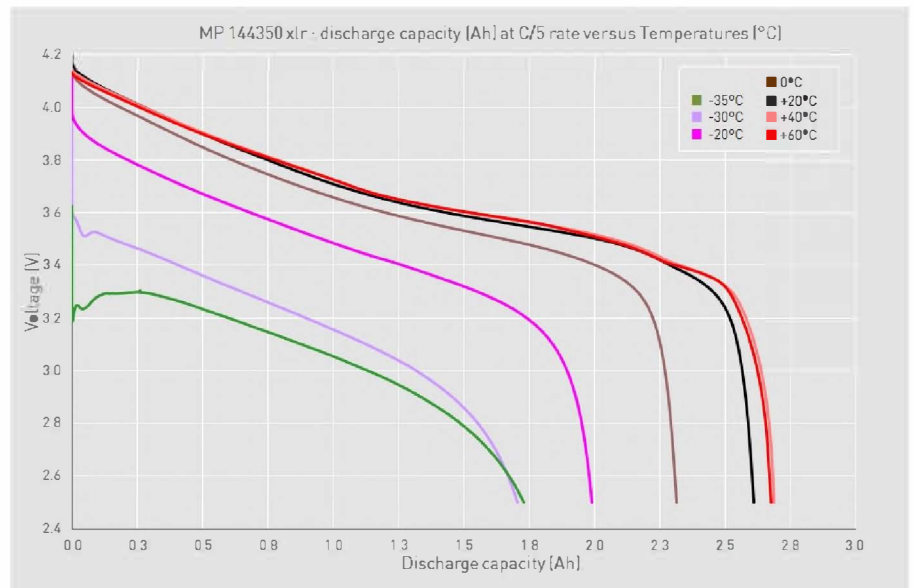
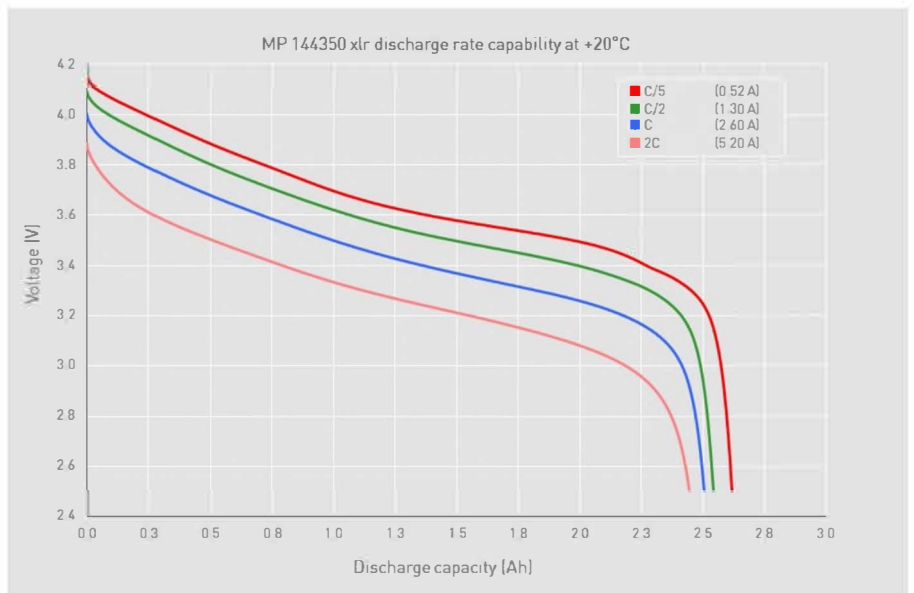

Battery safety

Single cell protection circuits

Electronic protection circuits for Li-ion 3.65 V MP xlr cells

The Saft 1s protection circuit is specifically designed to provide optimum protection for Li-ion batteries consisting of series assemblies from one to eight cells with a maximum number of one to six cells in parallel, depending on the maximum voltage. Other configurations are possible, please contact Saft for further information.

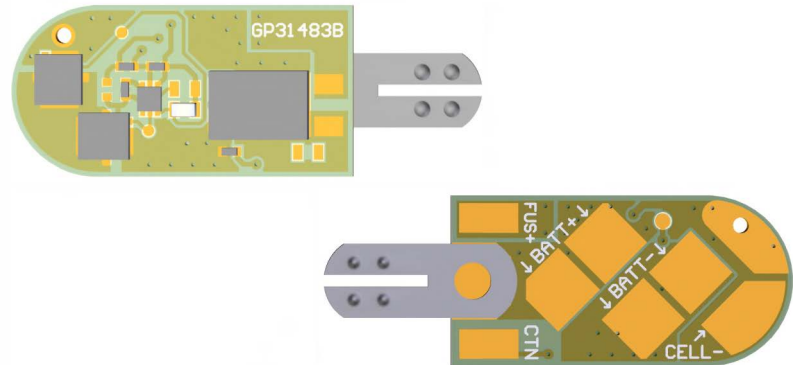

Benefits

- Safety management for battery assemblies
- Balancing during discharge depending on load
- Active mode and sleep mode
- Temperature performance from -40°C to +60°C
- Easy assembly into multi-cell batteries with the large solder pads
- High reliability

Key features

- Over voltage protection
- Under voltage protection
- Over current protection
- Short circuit protection
- Over temperature protection
- Fuse protection as an option
- NTC integrated in circuit
- Zero volt (0V) battery protection
- UL94-V0
- Made in the EU

Designed to meet all major quality, safety and environmental standards

- Quality: ISO 9001 Saft World Class program
- Environment: ISO 14001, RoHS and REACH as applicable.

Typical applications

- Backup for industrial equipment
- Medical devices
- Tracking applications
- Military applications
- Commercial applications
- General purpose industrial equipment.

Electrical characteristics—Voltage		Typical			
Voltage upper limit (VUL) at +25°C		4.275 ±0.020 V			
Voltage hysteresis upper limit (VHUL) at +25°C		4.075 ±0.050 V			
Delay time for VUL (TUL) at +25°C		1.00 ± 0.30 s			
Voltage lower limit (VLL) at +25°C		2.30 ± 0.050 V			
Voltage hysteresis lower limit (VHLL)		0 ± 0.000 V			
Delay time for VLL (TLL) at +25°C		0.128 ± 0.038 s			
Electrical characteristics—Current		5 Amp 1s circuit		10 Amp 1s circuit	
	Min	Max	Min	Max	
Current max		5A (60°C)		10A (60°C)	
Over current 1 detection (Ioc) at +25°C	8 A	18 A	24 A	34 A	
Over current 1 detection (Ioc) at +25°C	11 ± 2ms		11 ± 2ms		
Over current 2 detection (Ioc) at +25°C	27 A	55 A	60 A	80 A	
Over current 2 delay time (Iocd) at +25°C	4 ± 1.0ms		4 ± 1.0ms		
Reverse charge current limit	3 A		3 A		
Charge inhibition voltage	≤ 1.2 ± 0.3V		≤ 1.2 ± 0.3V		
Operational characteristics			Value		
Temperature sensor (NTC) @ +25°C			10kΩ		
Ceramic fuse			(optional)		
Maximum circuit consumption at +25°C			5 µA		
Maximum sleep mode circuit consumption			0.1 µA		
Operating temperature range			-40°C to +85°C		
Maximum voltage			6.0 V		
Dimension L x W x D (mm) (D=5.2mm with thermal fuse)			23.0 x 11.5 x 2.10		
Weight			1.0 g		
Operational MTBF			2.23 M hours		



Functions and operations

■ 0V Battery protection

For user safety, the battery cannot be recharged if the cell voltage falls below 1.2V ($\pm 0.3V$).

■ Over and under voltage

Battery voltage is monitored continuously and if the threshold is exceeded for a period longer than the Delay time, then the charge or discharge MOSFET is switched off interrupting the current. When the battery voltage falls back to the recovery threshold, the circuit will automatically reset.

■ Over current protection

There are two levels of protection against overcurrent in discharge, the first is from the charge and discharge MOSFET's and optionally a thermal fuse or micro fuse directly on the circuit board. The temperature may also be externally monitored via the NTC thermistor.

■ Cell balancing

Reduce cells' charge differences during the end of discharge when the current drops to ≤ 1 Amp. Batteries assembled from the 1s circuit may also be rebalanced after long periods of storage or use by discharging until 0V at ≤ 1 Amp. A well balanced multicell battery will have a longer runtime, and retain more capacity from cycle to cycle.

■ Storage

In the case of long duration storage, it is strongly recommend recharging the battery every 6 months to a level of 50% State of Charge. The storage area should be clean, cool (preferably not exceeding $+30^{\circ}C$), dry and ventilated.

Circuit board reference	Max (I) 5A	NTC ⁽¹⁾	Fuse/PPTC ⁽³⁾	Thermal fuse ⁽²⁾
GP 31485		Yes	(Optional)	(Optional)

Circuit board reference	Max (I) 10A	NTC ⁽¹⁾	Fuse/PPTC ⁽³⁾	Thermal fuse ⁽²⁾
GP 31486		Yes	(Optional)	(Optional)

⁽¹⁾ The NTC thermistor is fitted to all variants of the circuit board as a standard component. Its connection to and use by the end application is optional. ⁽²⁾ Where "(Optional)" is noted, the circuit board may have a $93^{\circ}C$ thermal fuse fitted externally as a standard component. ⁽³⁾ An SMD Fuse (non-resettable) or SMD PPTC (Polymer Positive Temperature Coefficient—resettable fuse) are readily available options mounted directly on the circuit board.

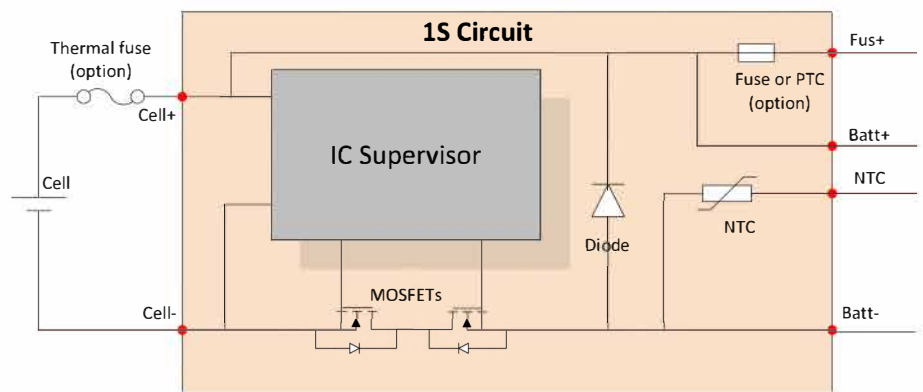

Above is a representative diagram of the main circuit components of the 1s protection circuit. The Thermal fuse, SMD Fuse and PPTC are available options.

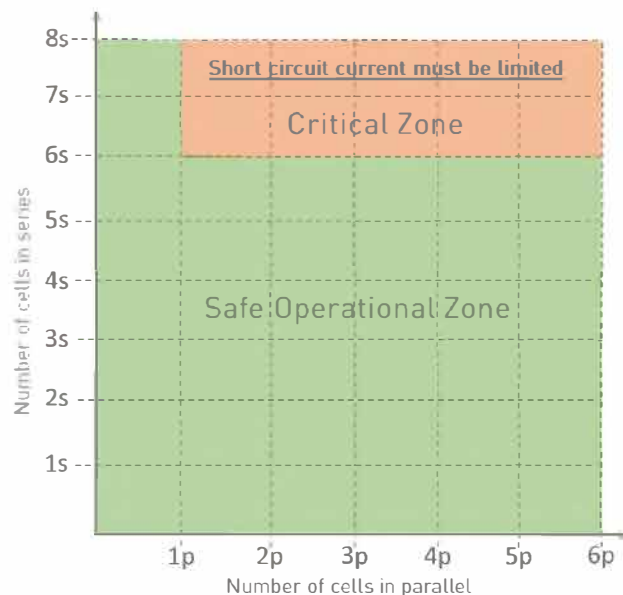

The above diagram depicts the maximum number of MP xlr cells in series and in parallel that can be constructed using the 1s circuit. The diagram is representative for an ambient temperature of $25^{\circ}C$ and a maximum external short circuit of $100m\Omega$.



Functions and operations

■ 0V Battery protection

For user safety, the battery cannot be recharged if the cell voltage falls below 1.2V ($\pm 0.3V$).

■ Over and under voltage

Battery voltage is monitored continuously and if the threshold is exceeded for a period longer than the Delay time, then the charge or discharge MOSFET is switched off interrupting the current.

When the battery voltage falls back to the recovery threshold, the circuit will automatically reset.

■ Over current protection

There are two levels of protection against overcurrent in discharge, the first is from the charge and discharge MOSFET's and optionally a thermal fuse or micro fuse directly on the circuit board. The temperature may also be externally monitored via the NTC thermistor.

■ Cell balancing

Reduce cells' charge differences during the end of discharge when the current drops to ≤ 1 Amp. Batteries assembled from the 1s circuit may also be rebalanced after long periods of storage or use by discharging until 0V at ≤ 1 Amp. A well balanced multicell battery will have a longer runtime, and retain more capacity from cycle to cycle.

■ Storage

In the case of long duration storage, it is strongly recommend recharging the battery every 6 months to a level of 50% State of Charge.

The storage area should be clean, cool (preferably not exceeding $+30^{\circ}C$), dry and ventilated.

Circuit board reference	Max (I) 5A	NTC ⁽¹⁾	Fuse ⁽⁴⁾	Thermal fuse ⁽³⁾
GP31444		Yes	[Optional]	Yes
GP31447		Yes	[Optional]	No
Circuit board reference	Max (I) 10A	NTC ⁽¹⁾	Fuse ⁽⁴⁾	Thermal fuse ⁽³⁾
GP31469		Yes	[Optional]	Yes
GP31471		Yes	[Optional]	No
Circuit board interconnection ⁽²⁾	NTC	Fuse	Thermal fuse	
GP16391	No	No	No	No

⁽¹⁾ The NTC thermistor is fitted to all variants of the circuit board as a standard component. Its connection to and use by the end application is optional. ⁽²⁾ The interconnection board contains no components and is used solely for the interconnection of cells in parallel when building a multicell battery. ⁽³⁾ Where "yes" is noted, the circuit board has a $117^{\circ}C$ thermal fuse fitted as a standard component. ⁽⁴⁾ An SMD Fuse (non-resettable) or SMD PPTC (Polymer Positive Temperature Coefficient—resettable) are readily available options.

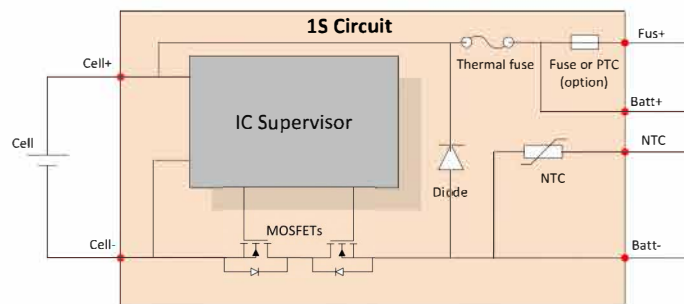

Above is a representative diagram of the main circuit components of the 1s protection circuit. The Thermal fuse, SMD Fuse and PPTC are available options.

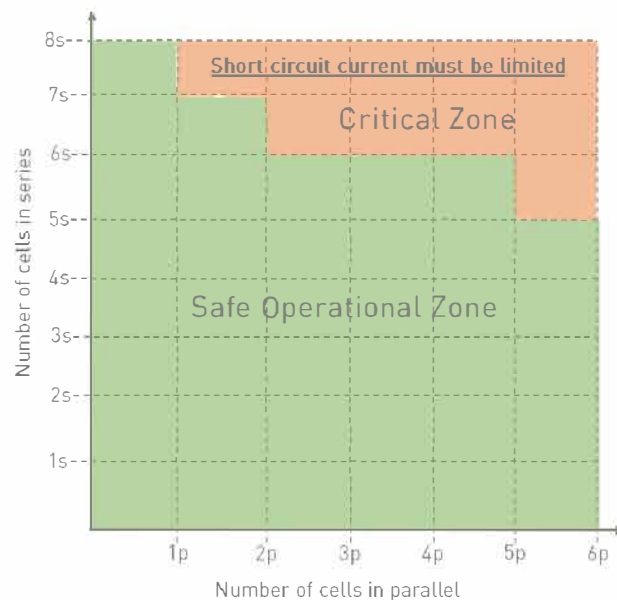

The above diagram depicts the maximum number of MP xtd/ise cells in series and in parallel that can be constructed using the 1s circuit. The diagram is representative for an ambient temperature of $25^{\circ}C$ and a maximum external short circuit of $100m\Omega$.



Архангельск (8182)63-90-72
Астана (7172)727-132
Астрахань (8512)99-46-04
Барнаул (3852)73-04-60
Белгород (4722)40-23-64
Брянск (4832)59-03-52
Владивосток (423)249-28-31
Волгоград (844)278-03-48
Вологда (8172)26-41-59
Воронеж (473)204-51-73
Екатеринбург (343)384-55-89
Иваново (4932)77-34-06

Ижевск (3412)26-03-58
Иркутск (395)279-98-46
Казань (843)206-01-48
Калининград (4012)72-03-81
Калуга (4842)92-23-67
Кемерово (3842)65-04-62
Киров (8332)68-02-04
Краснодар (861)203-40-90
Красноярск (391)204-63-61
Курск (4712)77-13-04
Липецк (4742)52-20-81

Киргизия (996)312-96-26-47

Магнитогорск (3519)55-03-13
Москва (495)268-04-70
Мурманск (8152)59-64-93
Набережные Челны (8552)20-53-41
Нижний Новгород (831)429-08-12
Новокузнецк (3843)20-46-81
Новосибирск (383)227-86-73
Омск (3812)21-46-40
Орел (4862)44-53-42
Оренбург (3532)37-68-04
Пенза (8412)22-31-16

Россия (495)268-04-70

Пермь (342)205-81-47
Ростов-на-Дону (863)308-18-15
Рязань (4912)46-61-64
Самара (846)206-03-16
Санкт-Петербург (812)309-46-40
Саратов (845)249-38-78
Севастополь (8692)22-31-93
Симферополь (3652)67-13-56
Смоленск (4812)29-41-54
Сочи (862)225-72-31
Ставрополь (8652)20-65-13

Казахстан (772)734-952-31

Сургут (3462)77-98-35
Тверь (4822)63-31-35
Томск (3822)98-41-53
Тула (4872)74-02-29
Тюмень (3452)66-21-18
Ульяновск (8422)24-23-59
Уфа (347)229-48-12
Хабаровск (4212)92-98-04
Челябинск (351)202-03-61
Череповец (8202)49-02-64
Ярославль (4852)69-52-93

www.sft.nt-rt.ru | | sfq@nt-rt.ru